

# 70x120

70JR120-300K SPUR GEARHEAD (正齿轮箱)  
w/ 42ZYT PM DC MOTOR (永磁直流马达)

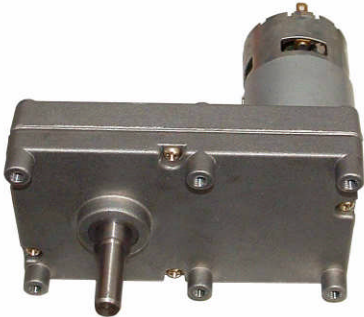

● GEARHEAD SPECIFICATIONS

Gear Ratio	Stage	Eff.	Rated Load	Max. Load
减速比	级数	效率	额定负载	最大负载
1:X	#	%	Kg.cm	Kg.cm / in-lb
134	3	66	200	600
394 - 863	4	59	250	750
1204 - 3084	5	53	300	900

● DIMENSIONS

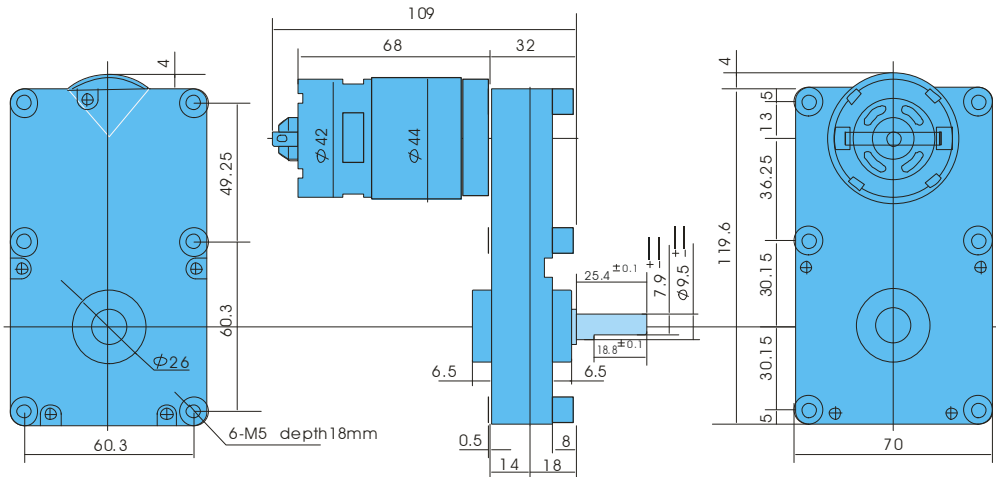

● MOTOR SPECIFICATIONS

Model	Rated	No-load		Rated				Stall	Motor	
	Voltage VDC	Current A	Speed r/min	Current A	Speed r/min	Torque g.cm	Power W	Torque g.cm	Dia. mm	Length mm
42ZYT67-12-25	12	0.2	2500	0.9	1850	300	5.7	1.2	42.2	67
42ZYT67-12-38	12	0.25	3800	1.8	2900	375	11.2	1.6	42.2	67
42ZYT67-12-50	12	0.55	5000	2.94	4200	460	19.8	2.8	42.2	67
42ZYT67-24-25	24	0.15	2500	0.45	1850	300	5.7	1.2	42.2	67
42ZYT67-24-38	24	0.13	3800	0.9	2900	375	11.2	1.6	42.2	67
42ZYT67-24-50	24	0.25	5000	1.46	4200	460	19.8	2.8	42.2	67

● GEAR MOTOR SPECIFICATIONS: 70JR120-300KxxxxG/ Motor model  $Y(IN-LB) = 0.867313 * X(Kg.cm)$

Volt.	Speed	Gear Ratio		134	394	494	664	720	733	863	1204	1269	1650	1927	2031	3084
		Efficiency %		73	66	66	66	66	66	66	66	59	59	59	59	59
12 Vdc	2500	Rated speed (RPM)		14	5	4	3	2.6	2.5	2.1	1.5	1.5	1.1	1.0	0.9	0.6
		Rated load (Kg.cm)		29.35	78.0	97.8	131.5	142.6	145.1	170.9	213.1	224.6	292.1	300	300	300
	3800	Rated speed (RPM)		22	7	6	4	4.0	4.0	3.4	2.4	2.3	1.8	1.5	1.4	0.9
		Rated load (Kg.cm)		36.7	97.5	122.3	164.3	178.2	181.4	213.6	266.4	281	300	300	300	300
	5000	Rated speed (RPM)		31	11	9	6	5.8	5.7	4.9	3.5	3.3	2.5	2.2	2.1	1.4
		Rated load (Kg.cm)		45.0	119.6	150.0	201.6	218.6	222.5	262.0	300	300	300	300	300	300
24 Vdc	2500	Rated speed (RPM)		14	5	4	3	2.6	2.5	2.1	1.5	1.5	1.1	1.0	0.9	0.6
		Rated load (Kg.cm)		29.35	78.0	97.8	131.5	142.6	145.1	170.9	213.1	224.6	292.1	300	300	300
	3800	Rated speed (RPM)		22	7	6	4	4.0	4.0	3.4	2.4	2.3	1.8	1.5	1.4	0.9
		Rated load (Kg.cm)		36.7	97.5	122.3	164.3	178.2	181.4	214	266	281	300	300	300	300
	5000	Rated speed (RPM)		31	11	9	6	5.8	5.7	4.9	3.5	3.3	2.5	2.2	2.1	1.4
		Rated load (Kg.cm)		45.0	119.6	150.0	201.6	219	223	262	300	300	300	300	300	300